

Thermometry System for Testing Temperature Variations in Super Conducting RF Cavities

Chris Bergevin

*Departments of Physics and Mathematics
University of Arizona, Tucson, AZ 85705*

Abstract

Thermometry systems have been employed to help map out loss mechanisms in superconducting rf cavities. These systems produce vast insight but prove to be cumbersome and difficult to work with. This paper describes a new thermometer design which has many advantages over the previous design and has a sensitivity in the submillikelvin range.

Introduction

Thermometry is an important tool in studying the characteristics of superconducting rf cavities. By measuring temperature variations on the surface of the cavity, vast insight can be obtained as to the complex events taking place inside the cavity. These events limit present acceleration gradients inside the cavity to less than one half the theoretical maximum. A typical temperature map of a 1.5 GHz cavity is shown in Figure 1.

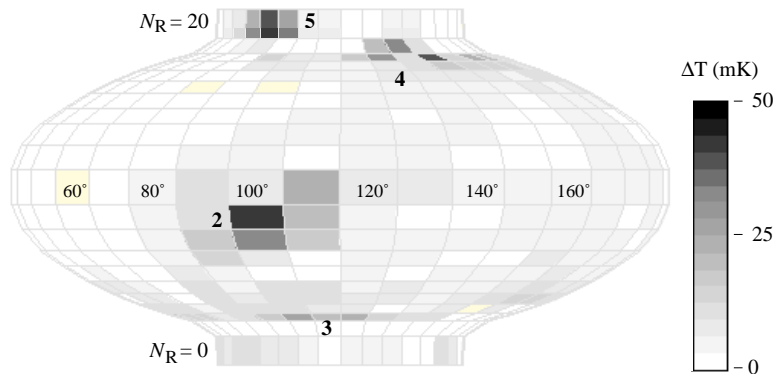

FIGURE 1. Typical temperature map of a cavity surface.

Several defects are revealed by anomalously large temperature signals due to excessive rf power dissipation. It is desirable to have thermometers which can obtain millikelvin resolution, are able to scan quickly, and are detachable. The thermometry system is set up so that the entire cavity surface is covered by thermometers. Such a system setup is shown in Figure 2.

The production of the thermometers has proven to be cumbersome and the rejection rate as well as the thermometer failure rate, is quite high. The purpose here is to describe a new thermometer design which is easier and more cost efficient to produce while being more robust.

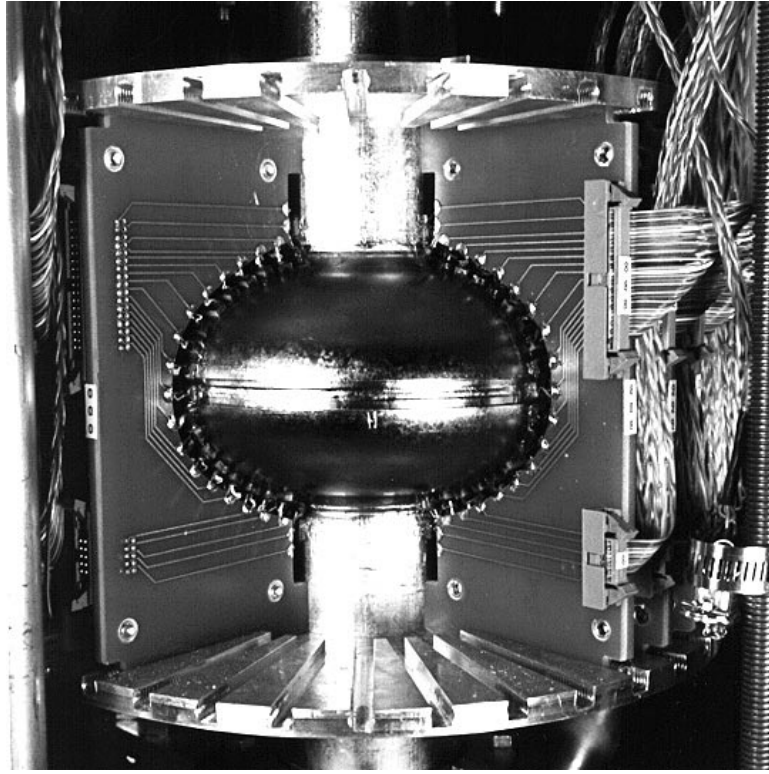

FIGURE 2. A 1.5 GHz cavity, partially covered by an array of thermometers.

Thermometer Design and Test Setup

Thermometer Characteristics

The thermometer design is based on a 100Ω , $1/8\text{W}$ Allen-Bradley resistor. As its temperature decreases, the resistance of the carbon resistor increases. In liquid helium, a small change in bath temperature produces a large change in the resistance ($\approx 10\Omega/\text{mK}$). This allows for small temperature variations to be measured. It is also desirable to have the thermometer design as small as possible. This would allow for more thermometers on the cavity surface, increasing the spatial resolution. A typical thermometer used in the past is shown in Figure 3.

The new design is basically the same size.

The cavity is operated in liquid helium with the thermometers placed on the outside of the cavity. The thermometers must be designed so that the liquid does not cool the thermometers excessively, which would interfere with cavity temperature measurements. One possibility is to encase the resistors in a material with a low thermal conductivity. This is done by cutting a groove in a G-10 board, fitting the resistor into the groove, and then sealing the groove with epoxy. The epoxy is then sanded down on one face so that the carbon of the resistor



FIGURE 3. Old thermometer design. The central dark region is the exposed carbon.

is exposed. This side is pressed against the surface of the cavity. A thin layer of varnish is applied to the face of the thermometer to electrically isolate the carbon from the cavity surface. Apeazon grease is also applied to the thermometer face in copious amounts so that the helium does not seep in between the thermometer and cavity surface.

In the older design, manganin wires (0.003 in.diameter), which have a low thermal conductivity, replaced the resistor leads. The leads must not conduct thermal energy from the thermometer, but at the same time, must make a solid connection to the encased resistor. The resistor was then encased as described above with the manganin wires fed through holes drilled into the G-10 board. A pogo stick was attached to the back of the thermometer to provide a force that keeps the thermometer face flush against the cavity surface. This design is shown in Figure 4.

The manganin wires proved to be the bane of this design as they were difficult to attach and frequently broke when flexed.

The new design eliminated the manganin wires completely and used pogo sticks as the resistor leads, as shown in Figure 5.

Again, the resistor was placed in the groove in the G-10 board. Two holes at the bottom to allow the resistor leads to pass through. They were cut off on the other side and a pogo stick was soldered to each of the leads (see Figure 5). The base of the pogo sticks have a conical indentation so that the resistor lead never actually touched the pogo stick. The electrical connection between the resistor lead and pogo stick was made only by the

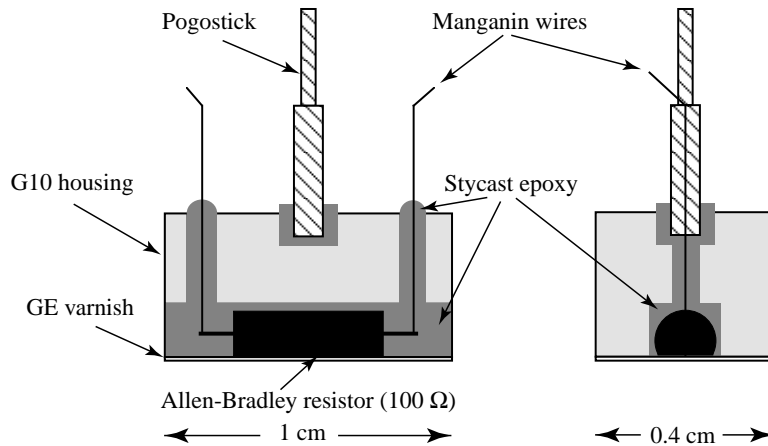

FIGURE 4. Old thermometer design, with manganin wires attached to the resistor leads.

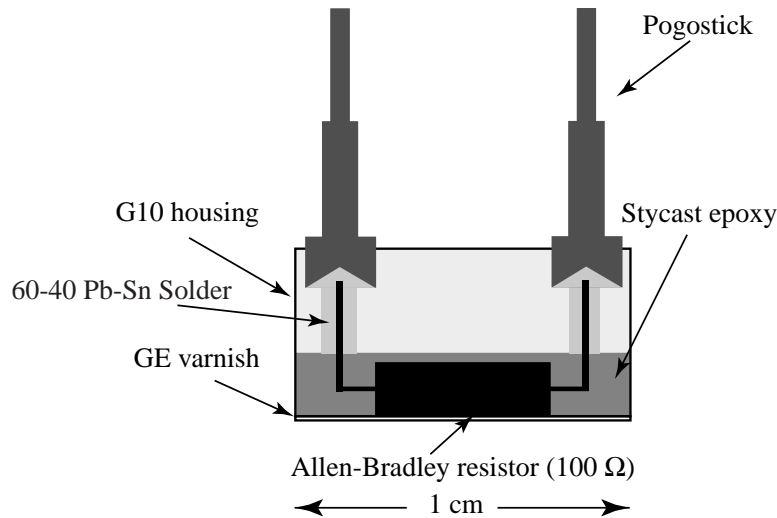

FIGURE 5. New thermometer design, including two pogo sticks as resist or leads.

solder. It is anticipated that the solder, which is made of lead-tin, is superconducting in the helium bath and hence has a low thermal conductivity. Thus, the solder will act as a thermal barrier to prevent cooling of the resistor. So far, this has not been investigated systematically. The pogo sticks add no significant resistance. They are rigid, making the thermometer more robust than the previous design. The two pogo sticks also allow for a greater contact pressure of the thermometer with the cavity surface and they prevent the thermometer from rotating. The production process was not very time consuming and holds the promise of easy mass production. While the new design has many advantages over the old, it still remains to be seen if this new design is as sensitive.

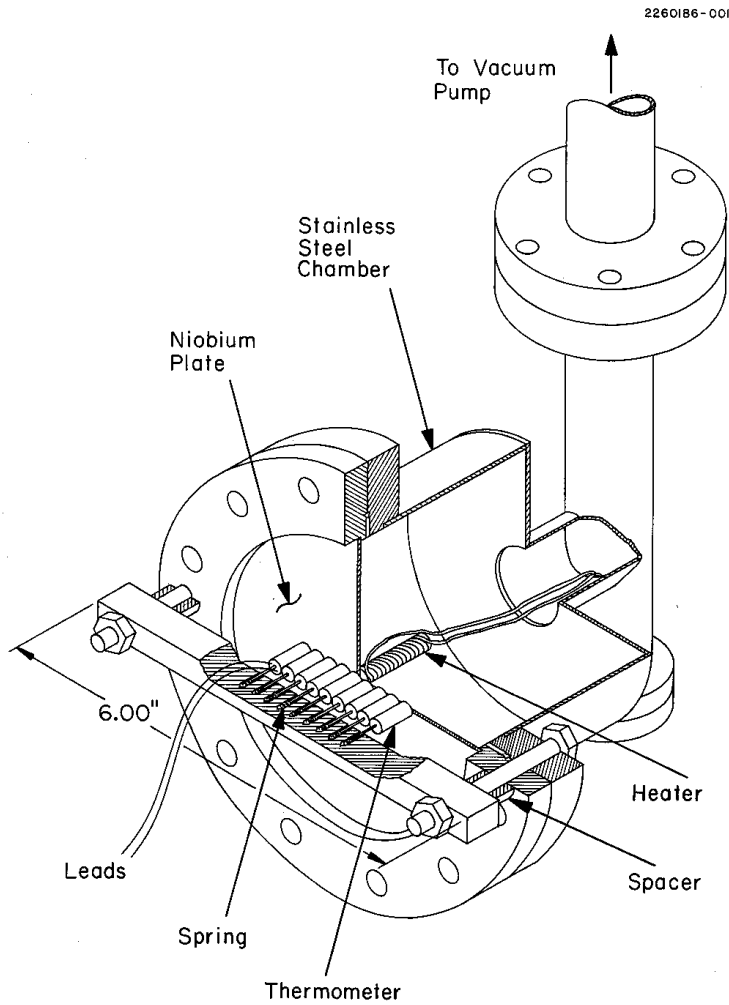

FIGURE 6. Thermometry test setup.

Test Setup

To test the new thermometers, the test setup in Figure 6 was used. A vacuum chamber with a flat niobium face was used. A niobium post was welded to the inside of this face with a resistive wire wrapped around it. Connections were made so that a known current could be run through the wire and the voltage drop could be measured, thus yielding the power delivered to the post. The chamber is evacuated to minimize conduction losses to the environment so that all heater power is delivered to face plate. A linear array of thermometers is then attached to the exterior face. The resistance of the thermometer is measured by applying a current and measuring the voltage drop across the resistor. After calibration, a temperature can be obtained from the resistance. Once these are calibrated, the temperature rise as a function of heater power is measured.

The thermometers were connected to a circuit board, which was also connected to a voltage source, as shown in Figure 7.

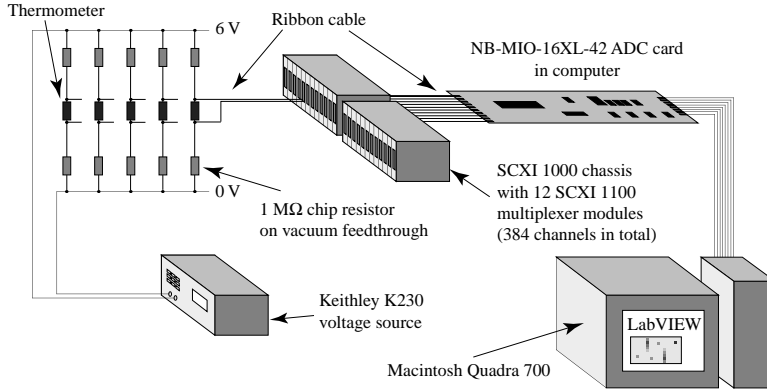

FIGURE 7. Basic overall design of thermometry test setup.

The board was designed so that the voltage drop across the thermometer could easily be measured. This is given by

$$\Delta V = V_{source} \frac{R_{therm}}{2 \times 10^6 + R_{therm}} \approx V_{source} \frac{R_{therm}}{2 \times 10^6} \quad (1)$$

R_{therm} being the resistance of the thermometer and V_{source} is the source voltage. The denominator represents the two $1 \text{ M}\Omega$ resistors soldered into the circuit board for each thermometer. These act like voltage dividers and since $2 \text{ M}\Omega \gg R_{therm}$, they provide a current source for each thermometer. They also have the effect of isolating each thermometer from the others.

The voltage drop across each thermometer is fed through the multiplexer to a data acquisition card on the Macintosh. Software was written in LabVIEW which would run the scanning and calibration routines. Connections to a germanium thermometer, used as a calibration standard, and the voltage source were made via a GPIB interface.

To calibrate the thermometers, the whole setup was dropped into a cryostat, which was then filled with liquid helium. A scan of the thermometers was made at 4.2K and the resistances calculated. The pressure of the bath was then lowered slowly, decreasing the bath temperature. During this process, the thermometers were scanned at user specified temperature intervals. The bath temperature was typically lowered to about 1.4K. At this point, the calibration data for each thermometer was fit to the following equation:

$$\frac{1}{T} = a + bx + cx^2 + dx^3 \quad (2)$$

where $x = \ln R_{therm}$ and T is the bath temperature measured by the germanium thermometer. Thus, four calibration constants were found for each thermometer. Once calibrated, measurement of the thermometer's resistance would yield its temperature using Eq. 1.

Measurements were made by taking a reading with the heater off, then another with it turned on. The temperature difference was then calculated and recorded. Measurements

were made mostly with the bath temperature at about 1.4K, but measurements were also made as a function of bath temperature, keeping the heater power constant.

Since the temperature is found by measuring a voltage drop across the thermometer, ohmic self heating is also an issue. The higher the excitation voltage is, the greater the accuracy of the measurement. But by increasing it, the thermometer tends to heat up, so a compromise must be made. Previous experiments with the old thermometer design found at 6V (across the $2M\Omega$ resistors), submillikelvin temperature signals could still be measured. Measurements were made to see if this was also acceptable for the new design. This was done by starting at an offset voltage, usually 1V, and making a scan of the thermometers. The voltage was then changed and another scan was made, thus yielding the temperature difference as a function of voltage difference.

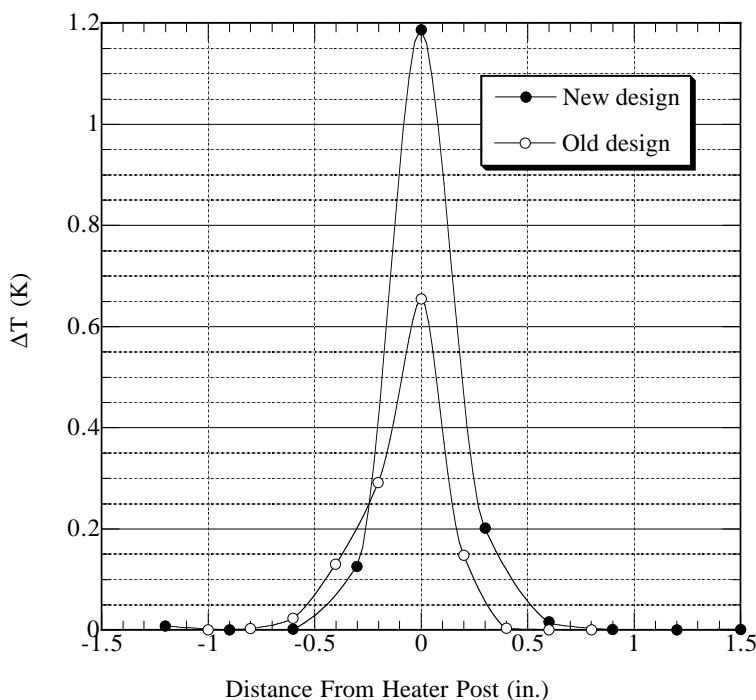

FIGURE 8. Temperature profile comparing new design to old. Heater power ≈ 100 mW. The asymmetry is due to misalignment of thermometers about center of plate.

Results

Temperature Profile

A temperature profile is shown in Figure 8. Notice that the readings for the center thermometer are quite high. These measurements were made at a high heater power, especially considering that we are interested in temperature measurements in the millikelvin range. Due to the strong cooling of the face plate by the helium bath, only the center thermometer responded significantly at lower heater powers. Thus, most of the information presented

below was obtained by the center thermometer.

Temperature Reading versus Heater Power

Previous measurements made in 1993 of temperature rise versus heater power demonstrated a linear dependence. This did not hold true for recent results. Figure 9 shows the plot for three thermometers of the new design and one for the old.

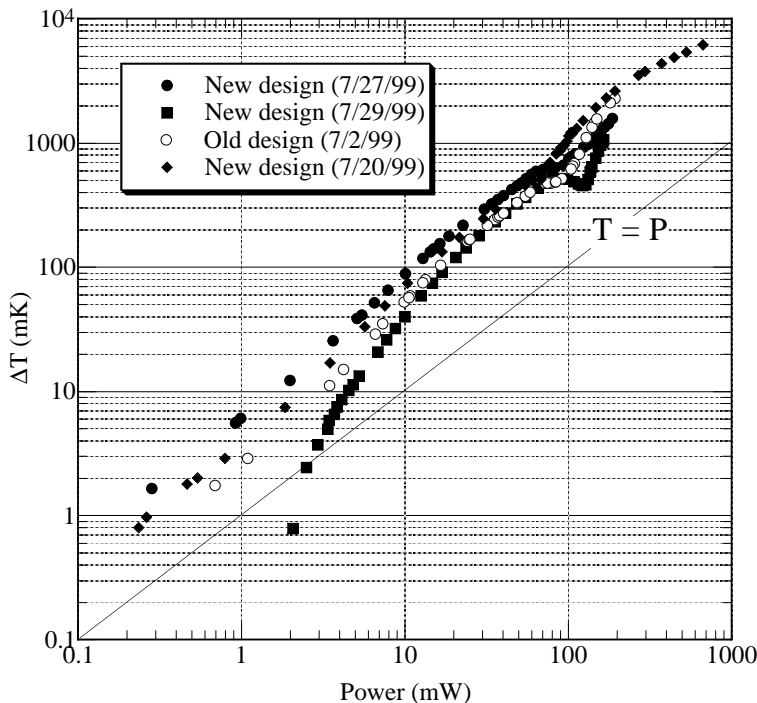

FIGURE 9. Temperature difference as a function of heater power for different center thermometers. Bath temperature = 1.4 K

We see that overall, the sensitivity of the new design is the same as that of the old. At low heater powers the behavior is near linear, but this is not so at higher heater powers. There are dips in the data at temperature differences around 600mK. The presence of these dips is not really understood, but might have something to do with the lambda point transition. This effect might be due to the test setup as thermometers used in a previous setup did not show this behavior. But when tested with the new setup, the presence of the dips can be seen, as shown in Figure 9.

Not all of the new thermometers performed to expectation. The run on 7/29/99 had a large dip and a lower sensitivity than the others, more drastically seen at lower temperatures. Whether or not this is a common occurrence can only be determined by further test with more thermometers.

Self Heating

As mentioned before, self heating is an issue. A voltage of 6V was acceptable for the old design to measure submillikelvin temperatures. The new design showed the new design is comparable to, if not better than the old design. This is shown in Figure 10.

Changing Bath Temperature

Both designs show similar sensitivity at 1.4K. As the bath temperature increases, the sensitivity changes. As shown in Figure 11, the sensitivity change stays more or less the same for both thermometers.

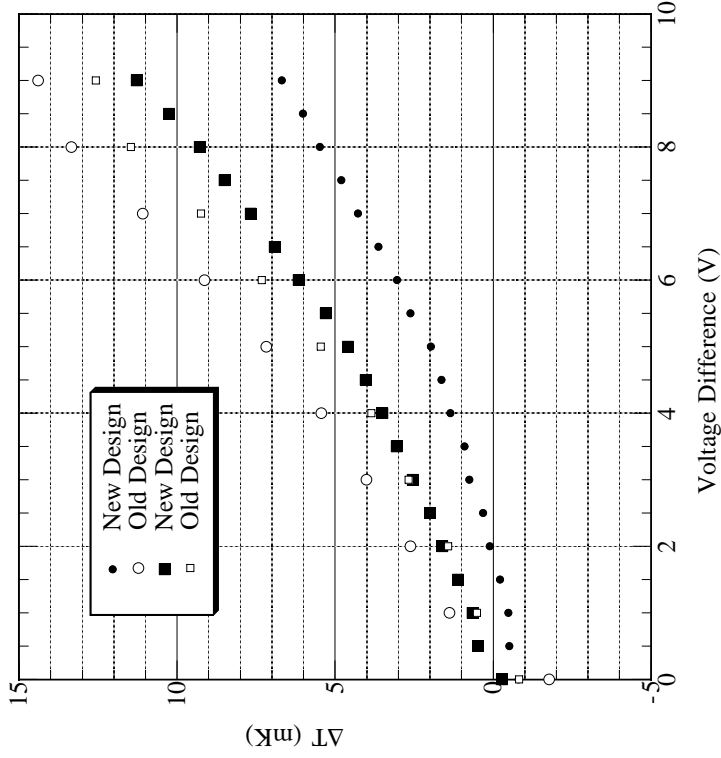

FIGURE 10. Self heating data. (Offset voltage = 1 V)

Mass Production Techniques

Various aspects of techniques for mass production of the new thermometer design were investigated. One idea is to create a setup so that the pogo sticks are placed on top of the G-10 board encasing the resistor with a piece of solder in between. There would be a downward force compressing the pogo sticks. This setup would then be placed into an oven and baked to a high enough temperature to melt the solder, thereby making the electrical connection between the pogo sticks and the resistor leads. This process could save a lot of time since each pogo stick is presently soldered by hand—a time consuming process.

Resistors have been baked to temperatures above the melting point of the solder used to make the connections, about 220°C. They have survived the baking process with a small decrease in resistance at room temperature, no more than 5Ω. These resistors have been tested and their calibration curves are similar to those of the unbaked thermometers, as shown in Figure 12.

Conclusions

The results demonstrate that the new design shows a lot of promise. In particular, the sensitivity is not diminished and this new design offers many advantages over the previous one. It is easier and more cost effective to make. Plans for mass production also show promise and have the effect of saving time and money.

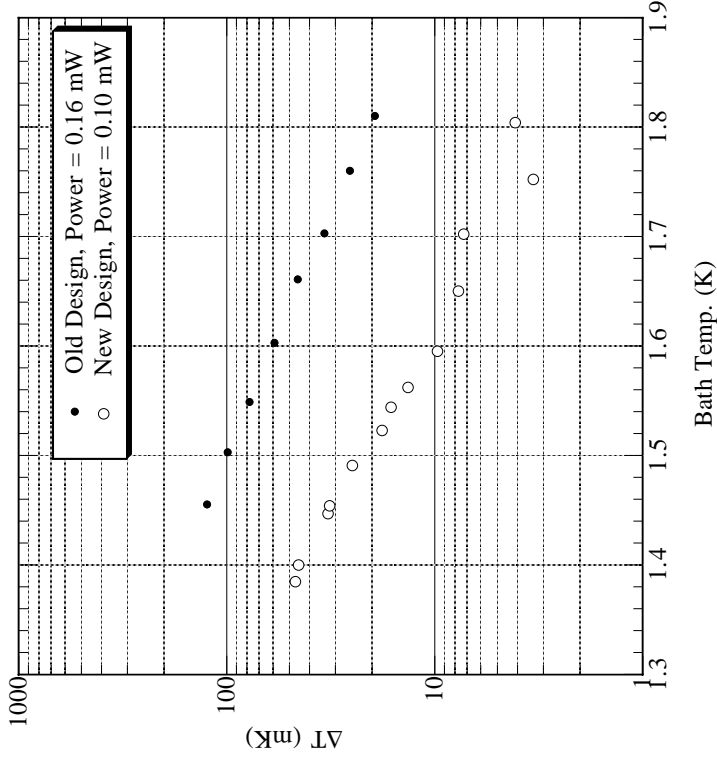

FIGURE 11. Temperature difference as a function of bath temperature at fixed power. Heater power was different for the two runs, but kept constant for each run.

At this point, more test still need to be done to confirm that the sensitivity of the new design does not vary from thermometer to thermometer. A first step would be a refinement of the test setup. If the face plate could have an annulus on the inside instead of a solitary post, more thermometers could be tested at once, saving time and resources. With this done, some more data would hopefully show the new design is capable of reproducing results from the old design.

Acknowledgments

I would like to thank Dr. Jens Knobloch of Cornell University, who proposed this Research Experience for Undergraduates project. He is just the greatest man to ever live. This work was supported by the National Science Foundation REU grant PHY-9731882 and research grant PHY-9809799.

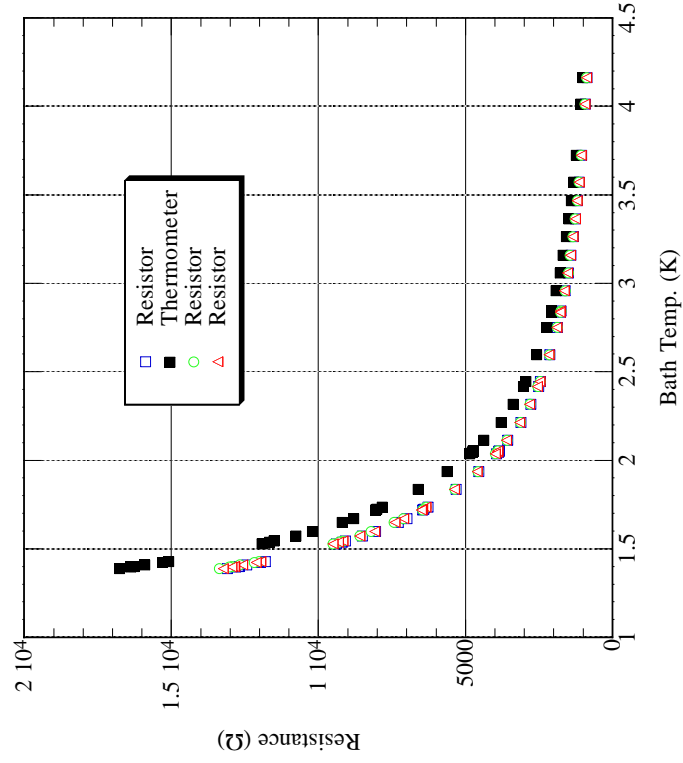

FIGURE 12. Calibration curve for three resistors and one thermometer. The resistors were all baked to 220°C, except for the resistor in the thermometer.