

CW MEASUREMENTS OF CORNELL LLRF SYSTEM AT HOBICAT*

A. Neumann[†], W. Anders, R. Goergen, J. Knobloch, O. Kugeler,
Helmholtz-Zentrum-Berlin, 12489 Berlin, Germany
S. Belomestnykh[‡], J. Dobbins, R. Kaplan, M. Liepe, C. Strohman,
Cornell University, Ithaca, NY 14853, USA

Abstract

In Energy Recovery Linacs, such as the Cornell ERL or BERLinPro, the main linac cavities are operated CW at low beam-loading. The choice of the external Q is given by two competing factors: The achievable field stability and the maximum provided RF power. To determine the optimum external Q, LLRF measurements with the Cornell system were performed at HoBiCaT to study the field stability at given microphonics detuning of a TESLA cavity for different gain settings and external Q values. Stable operation at external Q up to $2 \cdot 10^8$ was demonstrated at a field phase stability of 0.02 degrees.

INTRODUCTION

The Cornell Laboratory for Accelerator-based ScienceS and Education (CLASSE) plans for an X-ray light source based on Energy-Recovery-Linac (ERL) [1]. The Helmholtz-Zentrum Berlin is going to build the ERL demonstrator facility BERLinPro [2]. ERLs, suitable for light sources, need to accelerate high beam currents up to 100 mA. However, the high beam power is recovered in the cavities by the decelerated beam so, that the CW operated superconducting (SC) cavities of the main linac experience zero net beam loading.

In the case of no beam loading the needed RF power to establish a given accelerating voltage in a cavity is given by

$$P_f = \frac{V_{\text{acc}}^2}{4 \left(\frac{r}{Q}\right) Q_L} \left(1 + \left(\frac{\Delta f}{f_{1/2}}\right)^2\right) \quad (1)$$

with $\left(\frac{r}{Q}\right)$ the normalized shunt impedance in linac definition, Q_L the loaded quality factor, Δf the cavity detuning offset and $f_{1/2} = f_0/2Q_L$ the cavity half-bandwidth (as given in Figure 1). The optimal Q_L for minimized power requirements is therefore a function of the peak cavity detuning Δf_{peak} occurring during operation:

$$Q_{L,\text{opt}} = \frac{1}{2} \frac{f_0}{\Delta f_{\text{peak}}}. \quad (2)$$

This loaded Q will reduce the RF power requirements to save capital cost. Figure 1 displays the required forward RF power for a seven cell SC cavity operated at 20 MV/m

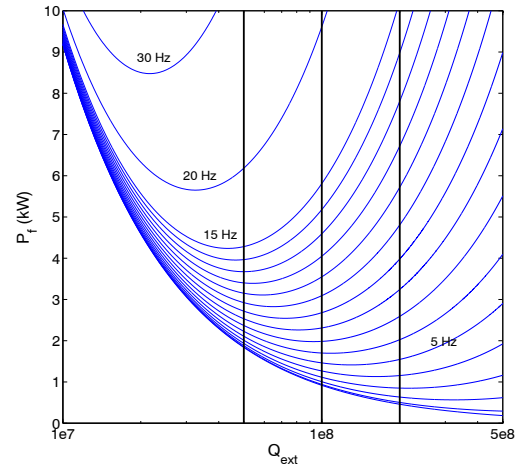

Figure 1: Required forward power for a seven cell superconducting cavity with $E_{\text{acc}}=20$ MV/m versus external quality factor Q_{ext} for different detuning (without beam-loading). The black lines denote the Q_{ext} analyzed in this work.

versus the loaded quality factor for different detuning levels. The three black lines denote the Q_L values analyzed in this work.

Choice of Q_L

Obviously the choice of the optimal Q_L has to fulfill two competing requirements. On the one hand for a given detuning Q_L has to be chosen such to minimize the required power level to maintain the desired accelerating voltage. On the other hand the required field stability limits the maximum Q_L as the cavity bandwidth decreases with higher Q_L . Narrow bandwidth operated cavities are even more susceptible to microphonics detuning and ponderomotive instabilities. ERLs typically require a field stability of better than 0.1 degrees RMS in phase and some 10^{-4} for the relative field amplitude [3]. Thus, before fixing on the design value for the loaded quality factor a measurement program has to demonstrate the following key questions and tasks:

- What is the microphonics detuning level at various cavity bandwidths? To what extent does a smaller cavity bandwidth filter out higher frequency detuning components? What are the noise sources triggering the microphonics detuning, especially peak events?

* Work supported by Bundesministerium für Bildung und Forschung and the Land Berlin.

[†] Axel.Neumann@helmholtz-berlin.de

[‡] now at Brookhaven National Laboratory, Upton, NY 11973, USA

- How often and to what detuning level do microphonics peak detuning events happen?
- What is the ultimately achievable field stability in amplitude and phase as a function of Q_L and loop gain? Does it fulfill the requirements of the ERL's beam dynamics?
- Find the optimum combination of mechanical detuning control by e.g. piezo based fast tuners and LLRF control settings. What are the optimal gain and filter settings?

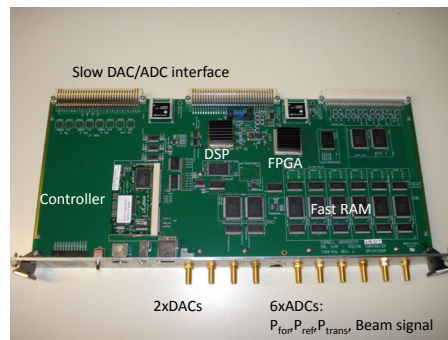

Figure 2: Picture of the Cornell LLRF digital board.

Further, in generator driven LLRF systems, the coupling of the Lorentz-force detuning to field amplitude fluctuations by strong microphonics may cause cavity field trips, so called ponderomotive instabilities. Also in ERLs the decelerated beam should cancel the beam loading of the accelerated beam perfectly, but due to time jitter of the beam, beam losses and small phase fluctuations of the beam in general, residual beam loading may occur. This needs to be compensated for by the LLRF system by supplying a small power overhead [5].

First tests at CEBAF and the Jefferson Lab FEL (with beam) using the Cornell system already demonstrated an operation up to $Q_L = 1.2 \cdot 10^8$ with phase stability around 0.02 degrees [6] in the energy-recovery mode. Intense studies of microphonics detuning and its compensation by means of piezo-based tuners had been done at HoBiCaT [7] and successful compensation up to Q_L of $1 \cdot 10^8$ reducing the detuning by about an order of magnitude was demonstrated.

In the following sections the measurements done at the HoBiCaT horizontal cavity test facility at HZB [8] in collaboration with Cornell will be presented.

SETUP AND MEASUREMENT PROGRAM

For the measurements at HoBiCaT a nine-cell TESLA cavity equipped with a TTF-III coupler, the Saclay I tuner including an improved piezo tuner [7] was installed. The new version of the Cornell LLRF system [4, 9] was commissioned using a new clock generation setup deriving all needed clock and reference signals directly from a low-noise fixed frequency 1.3 GHz reference source. A picture of the new digital board of the LLRF system including the FPGA for fast field control and the Tiger Shark DSP for detuning, operational and cavity trip control is given in Figure 1. Figure 3 shows the general scheme of the LLRF system and the clock and reference signal generation. The cavity field and power signals are downconverted to an intermediate frequency of 12.5 MHz of which the field components are detected via four times oversampling at 50 MHz. The cavity was driven via a 400 W solid state amplifier or alternatively by a 17 kW CPI IOT. Unfortunately the cavity was limited to only $E_{acc}=10$ MV/m due to strong field emission.

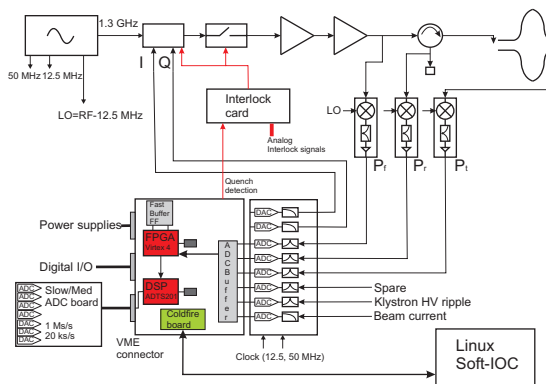

Figure 3: Scheme showing the functionality of the Cornell LLRF system.

Measurement Program

The aim of the measurements was to determine the optimal loaded Q and the achievable field stability in the presence of microphonics detuning and coupled dynamic Lorentz-force detuning. Further the additional detuning compensation for low frequency microphonics below the first mechanical eigenmode of the cavity should be demonstrated and finally the ramping of the cavity field from 1 to 10 MV/m at small cavity bandwidth of less than ten hertz in the presence of Lorentz-force detuning of the order of hundred hertz.

Finally, the aim was to optimize the setup of detuning and LLRF field control at highest Q_L possible still achieving the ERL's field stability requirements in a robust way.

DETUNING MEASUREMENTS

First the mechanical characteristics of the CW driven cavity was tested by measuring the piezo-to-RF detuning transfer function and the microphonics detuning spectrum [10]. The transfer function of the Saclay I tuner-cavity

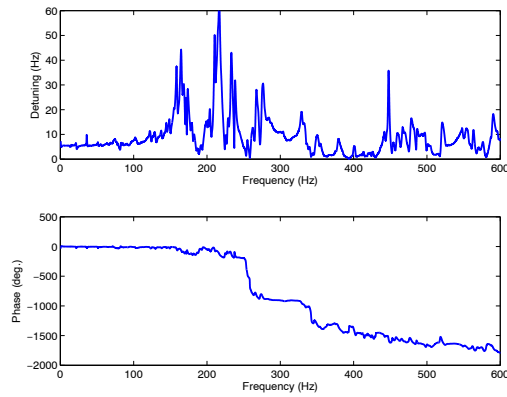

Figure 4: RF detuning transfer function in dependence of piezo tuner modulation frequency (upper plot). The lower plot shows the phase lag between piezo excitation signal and the cavity detuning response.

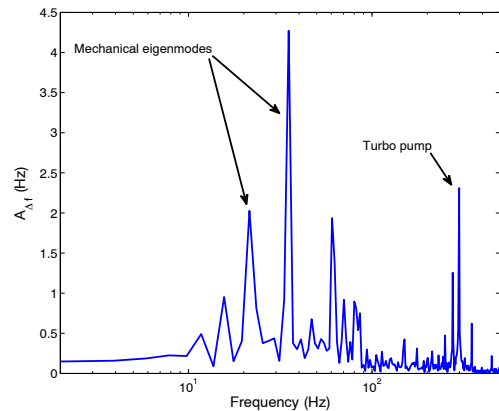

Figure 5: Detuning spectrum of a TESLA cavity operated CW at $Q_L = 5 \cdot 10^7$ and $E_{acc}=10$ MV/m. The data were taken by readout of the 100 kHz onboard ring buffer.

combination is shown in Figure 4 displays the detuning amplitude response and the phase lag between detuning and the piezo modulation frequency signal. The typical groups of mechanical eigenmodes between 150 and 350 Hz can be observed and also the first mechanical eigenmodes with a rather low response amplitude and a high mechanical quality factor at 21 Hz and 35 Hz. The phase response indicates a group delay of 240-300 μ s. Due to the narrow bandwidth in general well below 50 Hz, most high frequency components are filtered by the cavity itself and only the first two eigenmodes are present in the detuning spectrum given in Figure 5. Data taken at Q_L of $5 \cdot 10^7$ showed an RMS detuning of 4 Hz with 15 Hz peak detuning. A first commissioning of the LLRF's piezo control loop showed the limitation of the loop gain by the first mechanical eigenmode. To suppress any excitation only low gains with lowpass filtering below 1 Hz were possible. In the following tests the detuning control was therefore mainly used to control slow drifts

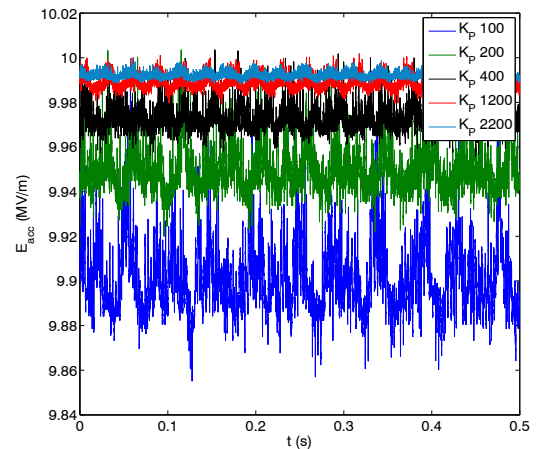

Figure 6: Cavity field amplitude (E_{acc}) versus time for different proportional gains K_P at $Q_L = 5 \cdot 10^7$.

by helium pressure fluctuations and to compensate detuning during the field ramping.

FIELD STABILITY MEASUREMENTS

After successfully closing the LLRF loop at $Q_L=5 \cdot 10^7$ an excitation of the $8/9-\pi$ passband mode about 800kHz below the π -mode damped by 70dB was observed. As predicted by control theory calculations this lead to instabilities of the loop oscillating with 15.8 kHz at a proportional gain of 1100. Changing the main loops filter settings to suppress the next passband mode and further optimization of the loop gain resulted in a stability of $\sigma_\Phi=0.01$ degree and relative amplitude error of $6 \cdot 10^{-5}$. At that time the reference source had a malfunction so that all measurements presented in the following had to be done by a standard frequency synthesizer. This had a factor of four worse phase noise characteristics limiting the achievable stability.

Figures 6 and 7 show the first gain scans at field levels of 10 MV/m and $Q_L = 5 \cdot 10^7$ for different proportional gains K_P and zero integral gain. The residual error follows as expected the $1/(1+K_P)$ dependance and at low gains of 100-200 strong coupling between phase and amplitude errors hint at microphonics amplified by Lorentz-force detuning.

Gain Scans versus Q_L

Figures 8, 9 and 10 summarize the gain scans performed at Q_L of $5 \cdot 10^7$, $1 \cdot 10^7$ and $2 \cdot 10^8$. Shown is in log scale as a color code the achieved RMS phase stability for a given setting of integral and proportional gains. The best values achieved are marked by red or dark blue spots. White areas denote results with phase errors higher than 0.1 degree or cavity field trips. Cavity field trips were caused by intrinsically instable gain settings or ponderomotive instabilities due to too low feedback gain leading to higher residual amplitude deviations. In Table 1 the results of

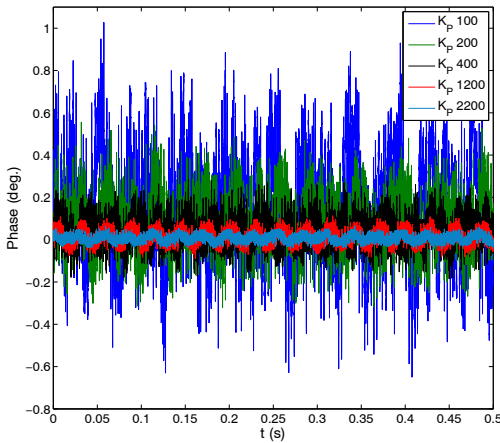

Figure 7: Cavity field phase versus time for different proportional gains K_P at $Q_L = 5 \cdot 10^7$.

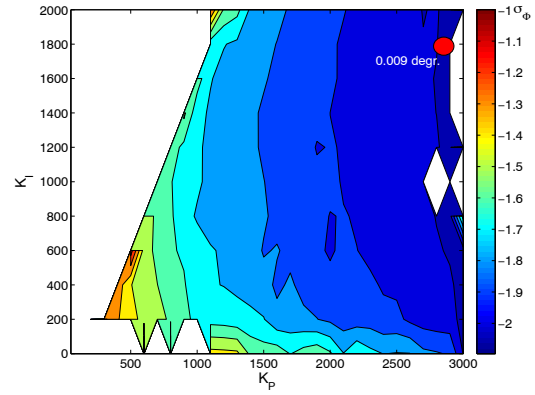

Figure 9: RMS phase stability (log scale) of the cavity field for different integral (K_I) and proportional gain settings at $Q_L = 1 \cdot 10^8$. The red dot marks the achieved absolute minimum of this gain scan.

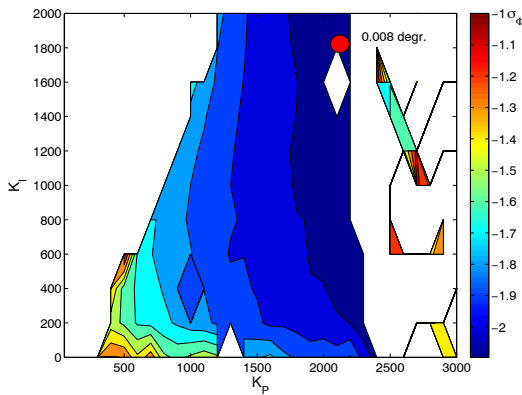

Figure 8: RMS phase stability (log scale) of the cavity field for different integral (K_I) and proportional gain settings at $Q_L = 5 \cdot 10^7$. The red dot marks the achieved absolute minimum of this gain scan.

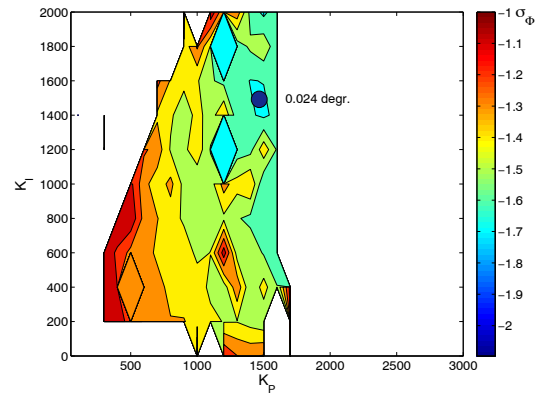

Figure 10: RMS phase stability (log scale) of the cavity field for different integral (K_I) and proportional gain settings at $Q_L = 2 \cdot 10^8$. The dark blue dot marks the achieved absolute minimum of this gain scan.

the gain scans are summarized. For 10 MV/m in all three cases the cavity could be operated at about 1 kW power or below. Depending on the cavity bandwidth the RMS microphonics level varied from 4-9 Hz. Best field stability was achieved for the lowest Q_L as expected, but also at $2 \cdot 10^8$, a half-bandwidth of only 3.25 Hz(!), the cavity was operated with a very high stability of about 0.02 degree phase deviation. During the measurements the piezo

ling the cavity in the sub-hertz regime. Also ramping of the cavity field within 1 second to 10 MV/m was demonstrated for all three quality factors.

OUTLOOK

In summary the measurements showed that a loaded quality factor of $5 \cdot 10^7$ - $1 \cdot 10^8$ is feasible achieving highest field stabilities. Even at peak detuning of 15 Hz about 5 kW of installed RF power would suffice to stably operate the cavity at 20 MV/m.

Nevertheless, future measurements with a better performing cavity have to demonstrate operation at field gradients as high as 20 MV/m and a reliable long term operation with an automated field recovery after a cavity trip. Further, it is planned to improve the performance of the piezo tuner algorithm to effectively cancel microphonics detuning, maybe allowing operation at even higher Q_L .

Table 1: Cavity field stability results at $E_{acc}=10$ MV/m

Q_L	σ_f (Hz)	σ_ϕ (deg)	σ_A/A	P_f (kW)
$5.0 \cdot 10^7$	9.5	0.008	$1 \cdot 10^{-4}$	1.106
$1.0 \cdot 10^7$	7.9	0.0093	$2 \cdot 10^{-4}$	0.595
$2.0 \cdot 10^6$	4.2	0.024	$3 \cdot 10^{-4}$	0.324

control loop mainly kept the cavity on resonance control-

ACKNOWLEDGEMENTS

We would like to thank the personal at both laboratories for supporting this work, especially the IT departments in supporting the transfer of the LLRF system in the HZB/BESSY EPICS environment. Further thanks to Sascha Klauke, Michael Schuster, Andre Frahm, Dirk Pflückhahn and Stefan Rotterdam for supporting the operation of HoBiCaT. We also would like to acknowledge Klaus Ludwig's design of the new clock and reference system.

REFERENCES

- [1] J.A: Crittenden *et al.*, "Developments for Cornell's X-ray ERL", Proc. of the 23rd PAC (2009), Vancouver, Canada, <http://www.JACoW.org>.
- [2] M. Abo-Bakr *et al.*, "BERLinPro- An Accelerator Demonstration Facility for ERL-based Light Sources", Proc. of the 25th LINAC (2010), Tsukuba, Japan, <http://www.JACoW.org>.
- [3] M. Liepe, S. Belomestnykh, "'RF Parameter and Field Stability Requirements for the Cornell ERL Prototype', Proc. of the 20th PAC (2003), Portland, USA, <http://www.JACoW.org>.
- [4] M. Liepe *et al.*, "Experience with the New Digital RF Control System at the CESR Storage Ring", Proc. of the 21st PAC (2005), Knoxville, USA, <http://www.JACoW.org>.
- [5] M. Liepe, J. Knobloch, "Superconducting RF for energy-recovery-linacs", Nuclear Instrumentes and Methods in Physics Research A, 557 (2006), pp. 354-369.
- [6] M. Liepe *et al.*, "Pushing the limits: RF field control at high loaded Q", Proc. of the 21st PAC (2005), Knoxville, USA, <http://www.JACoW.org>.
- [7] A. Neumann, W. Anders, O. Kugeler, J. Knobloch, "Analysis and active compensation of microphonics in continuous wave narrow-bandwidth superconducting cavities", Phys. Rev. ST Accel. Beams **13**, 082001, 2010.
- [8] O. Kugeler, A. Neumann, W. Anders, and J. Knobloch, "Adapting TESLA technology for future cw light sources using HoBiCaT", Review of scientific instruments, vol. 81, Jul. 2010, p. 074701.
- [9] M. Liepe, S. Belomestnykh, J. Dobbins, R. Kaplan, C. Strohman, "A new Digital Control System for CESR-C and the Cornell ERL", Proc. of the 20th PAC (2003), Portland, USA, <http://www.JACoW.org>.
- [10] A. Neumann, "Compensating microphonics in SRF Cavities to ensure beam stability for future Free-Electron-Lasers", Phd thesis, Humboldt Universität Berlin, Germany, 2008.