

REVISIONS			
SYM.	ZONE	DESCRIPTION	DATE APP.

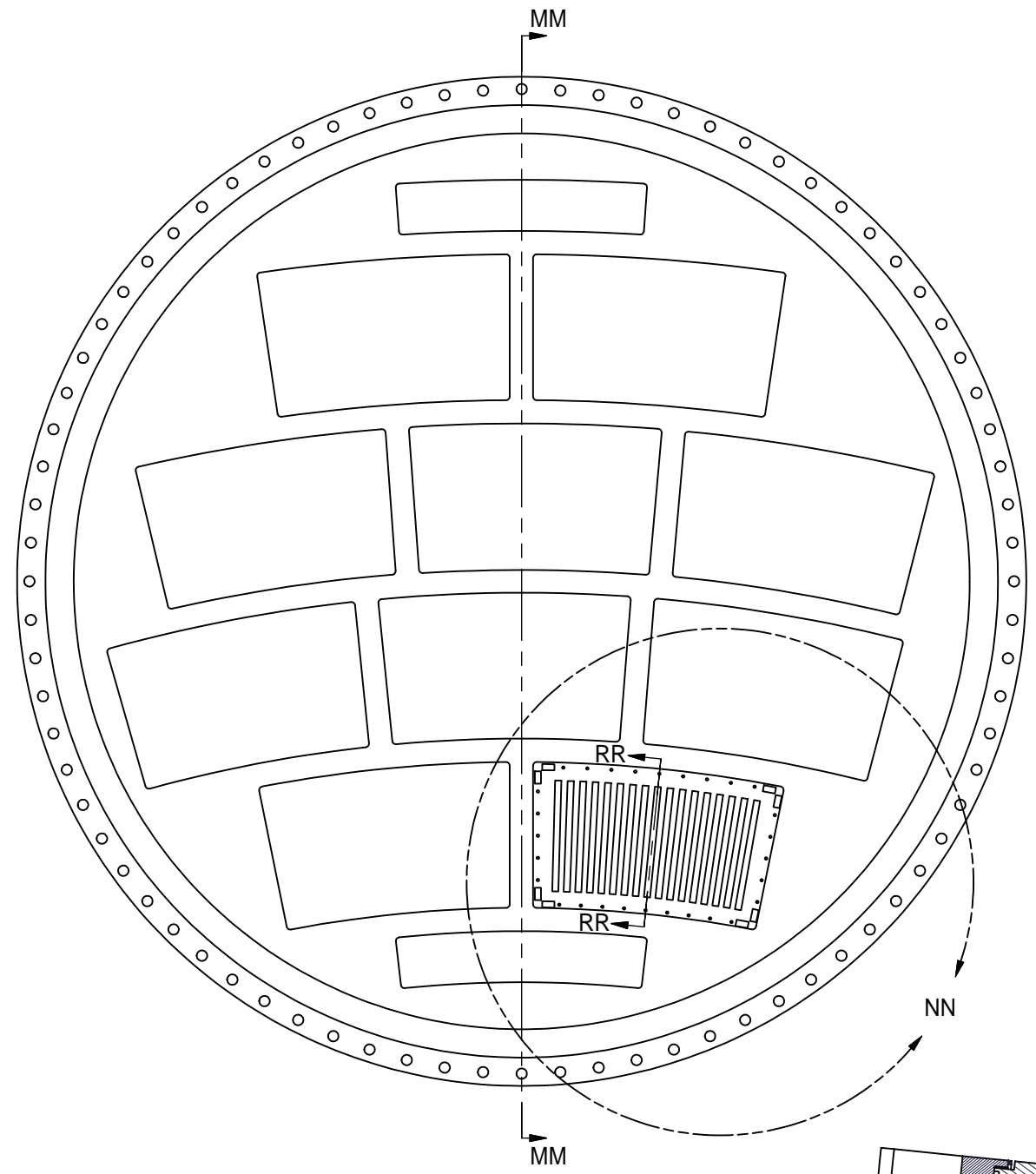

FRONT VIEW

NOTE: IN THIS VIEW MODULES ARE REGISTERED TO THE BOTTOM AND TO THE RIGHT

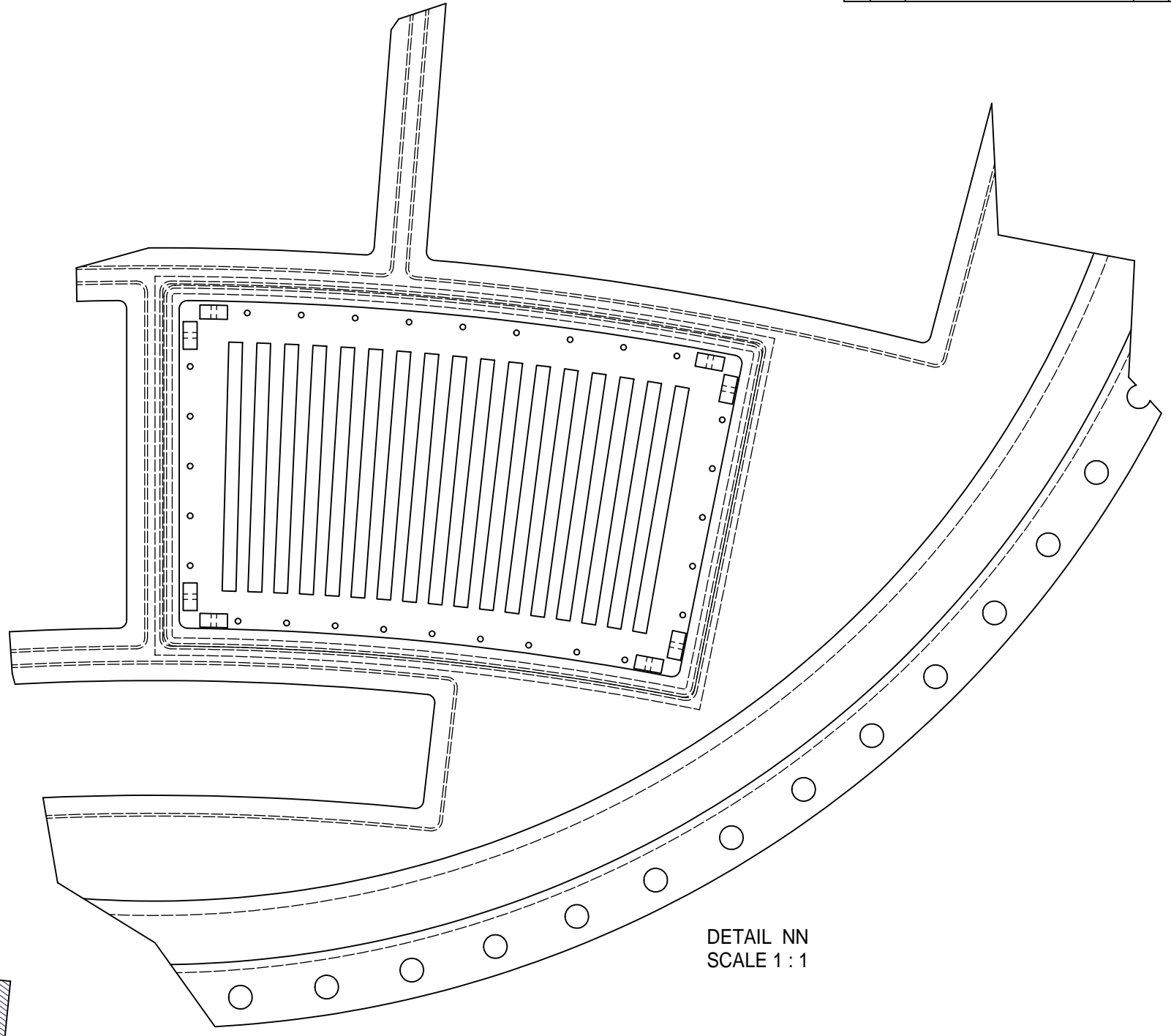

DETAIL NN
SCALE 1 : 1

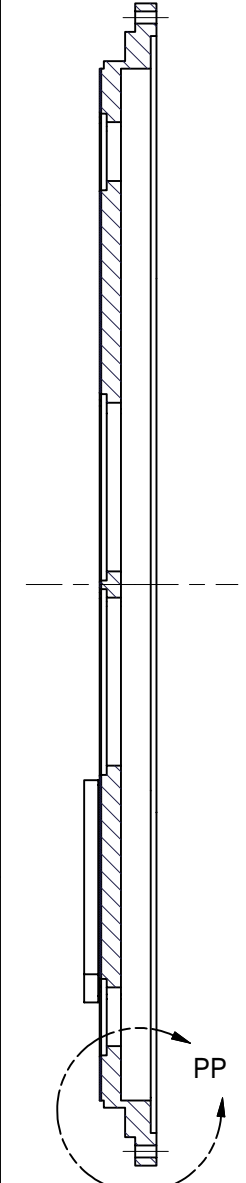

SECTION MM-MM
SCALE 3 / 8

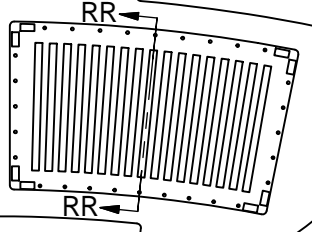

SECTION RR-RR
SCALE 1 : 1

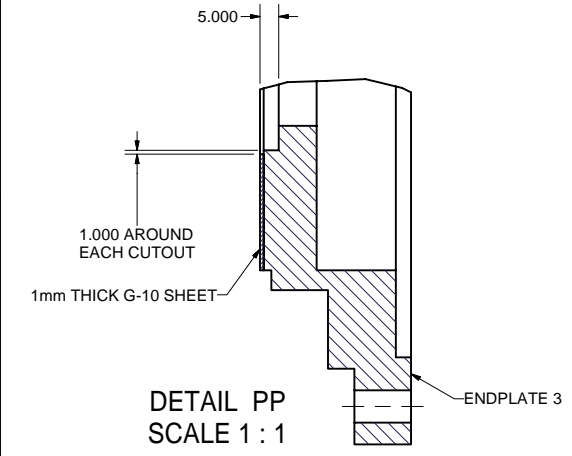

DETAIL PP
SCALE 1 : 1

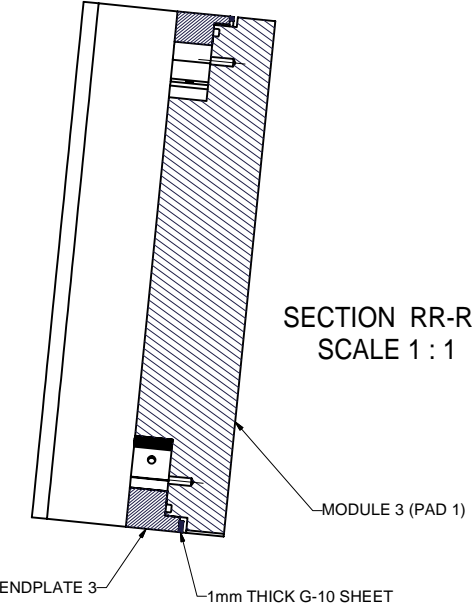

ENDPLATE 3
1mm THICK G-10 SHEET

FOR MACHINING LUBRICANT USE ONLY
ALKALINE DETERGENT LUBRICANT CIMSTAR 40
OR EQUIVALENT APPROVED BY CORNELL LEPP

REV.	PRINT DISTR.	ITEM	DWG. NO.	DESCRIPTION	G1	G2	G3	REMARKS	REV.
					QUANTITY				
D				PLOT DATE: 4/11/2006 CAD FILE NAME: 6080-014.idw					
6080-014 SH. NO. 16 OF 16	CR-1			UNLESS OTHERWISE SPECIFIED: DIMENSIONS ARE IN INCHES: TOLERANCES ON: .00 ±.010 .000 ±.005 FRACTIONS ±1/64 ANGLES ±0.5° ALL SURFACES ✓				CORNELL UNIVERSITY Floyd R. Newman Laboratory Ithaca, NY 14853	
				CHECKED BY:	DRAWN BY	DRAWN FOR	DATE	SCALE	D
				APPROVED BY:	TMK	DPP	4/4/2006		6080-014 SH. NO. 16 OF 16