



## MM74C925, MM74C926, MM74C927, MM74C928 4-Digit Counters with Multiplexed 7-Segment Output Drivers

### general description

These CMOS counters consist of a 4-digit counter, an internal output latch, NPN output sourcing drivers for a 7-segment display, and an internal multiplexing circuitry with four multiplexing outputs. The multiplexing circuit has its own free-running oscillator, and requires no external clock. The counters advance on negative edge of clock. A high signal on the Reset input will reset the counter to zero, and reset the carry-out low. A low signal on the Latch Enable input will latch the number in the counters into the internal output latches. A high signal on Display Select input will select the number in the counter to be displayed; a low level signal on the Display Select will select the number in the output latch to be displayed.

The MM74C925 is a 4-decade counter and has Latch Enable, Clock and Reset inputs.

The MM74C926 is like the MM74C925 except that it has a display select and a carry-out used for cascading counters. The carry-out signal goes high at 6000, goes back low at 0000.

The MM74C927 is like the MM74C926 except the second most significant digit divides by 6 rather than 10. Thus, if the clock input frequency is 10 Hz, the display would read tenths of seconds and minutes (i.e., 9:59.9).

The MM74C928 is like the MM74C926 except the most significant digit divides by 2 rather than 10 and the

carry-out is an overflow indicator which is high at 2000, and it goes back low only when the counter is reset. Thus, this is a 3 1/2-digit counter.

### features

- Wide supply voltage range 3V to 6V
- Guaranteed noise margin 1V
- High noise immunity 0.45  $V_{CC}$  typ
- High segment sourcing current 40 mA @  $V_{CC} = 1.6V, V_{CC} = 5V$
- Internal multiplexing circuitry

### design considerations

Segment resistors are desirable to minimize power dissipation and chip heating. The DM75492 serves as a good digit driver when it is desired to drive bright displays. When using this driver with a 5V supply at room temperature, the display can be driven without segment resistors to full illumination. The user must use caution in this mode however, to prevent overheating of the device by using too high a supply voltage or by operating at high ambient temperatures.

The input protection circuitry consists of a series resistor, and a diode to ground. Thus input signals exceeding  $V_{CC}$  will not be clamped. This input signal should not be allowed to exceed 15V.

### connection diagrams

Dual-In-Line Package  
MM74C925

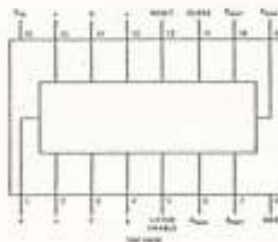

Dual-In-Line Package  
MM74C926, MM74C927 and MM74C928

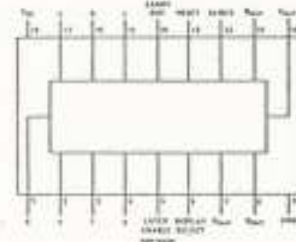

### functional description

- Reset — Asynchronous, active high
- Display Select — High, displays output of counter  
Low, displays output of latch
- Latch Enable — High, flow through condition  
Low, latch condition
- Clock — Negative edge sensitive

- Segment Output — Current sourcing with 80 mA @  $V_{OUT} = V_{CC} - 1.6V$  typical. Also, sink capability = 2 LTTL loads
- Digit Output — Current sourcing with 1 mA @  $V_{OUT} = 1.75V$ . Also, sink capability = 2 LTTL loads
- Carry-out — 2 LTTL loads. See carry-out waveforms.

**absolute maximum ratings (Note 1)**

Voltage at Any Output Pin	Gnd - 0.3V to V <sub>CC</sub> +0.3V
Voltage at Any Input Pin	Gnd - 0.3V to +15V
Operating Temperature Range (T <sub>A</sub> )	-40°C to +85°C
Storage Temperature Range	-65°C to +150°C
Package Dissipation	Refer to P <sub>D(MAX)</sub> vs T <sub>A</sub> Graph
Operating V <sub>CC</sub> Range	3V to 6V
V <sub>CC</sub>	6.5V
Lead Temperature (Soldering, 10 seconds)	300°C

**dc electrical characteristics** Min/max limits apply at -40°C ≤ T<sub>J</sub> ≤ +85°C, unless otherwise noted.

PARAMETER	CONDITIONS	MIN	TYP	MAX	UNITS
<b>CMOS TO CMOS</b>					
V <sub>INT1</sub>	Logical "1" Input Voltage	V <sub>CC</sub> = 5.0V	3.5		V
V <sub>INT0</sub>	Logical "0" Input Voltage	V <sub>CC</sub> = 5.0V		1.5	V
V <sub>OUT11</sub>	Logical "1" Output Voltage (Carry-out and Digit Output Only)	V <sub>CC</sub> = 5.0V, I <sub>O</sub> = -10μA	4.5		V
V <sub>OUT10</sub>	Logical "0" Output Voltage	V <sub>CC</sub> = 5.0V, I <sub>O</sub> = 10μA		0.5	V
I <sub>INT1</sub>	Logical "1" Input Current	V <sub>CC</sub> = 5.0V, V <sub>IN</sub> = 15V		0.005	μA
I <sub>INT0</sub>	Logical "0" Input Current	V <sub>CC</sub> = 5.0V, V <sub>IN</sub> = 0V	-1.0	-0.005	μA
I <sub>CC</sub>	Supply Current	V <sub>CC</sub> = 5.0V, Outputs Open Circuit, V <sub>IN</sub> = 0V or 5V	20	1000	μA
<b>CMOS/LPTTL INTERFACE</b>					
V <sub>INT1</sub>	Logical "1" Input Voltage	V <sub>CC</sub> = 4.75V	V <sub>CC</sub> -1.5		V
V <sub>INT0</sub>	Logical "0" Input Voltage	V <sub>CC</sub> = 4.75V		0.8	V
V <sub>OUT11</sub>	Logical "1" Output Voltage (Carry-Out and Digit Output Only)	V <sub>CC</sub> = 4.75V, I <sub>O</sub> = -360μA	2.4		V
V <sub>OUT10</sub>	Logical "0" Output Voltage	V <sub>CC</sub> = 4.75V, I <sub>O</sub> = 360μA		0.4	V
<b>OUTPUT DRIVE</b>					
V <sub>OUT</sub>	Output Voltage (Segment Sourcing Output)	I <sub>OUT</sub> = -65 mA, V <sub>CC</sub> = 5V, T <sub>J</sub> = 25°C	V <sub>CC</sub> -1.6	V <sub>CC</sub> -1.3	V
		I <sub>OUT</sub> = -40 mA, V <sub>CC</sub> = 5V		V <sub>CC</sub> -1.2	V
		T <sub>J</sub> = 100°C		V <sub>CC</sub> -1.4	V
		T <sub>J</sub> = 150°C			V
R <sub>ON</sub>	Output Resistance (Segment Sourcing Output)	I <sub>OUT</sub> = -65 mA, V <sub>CC</sub> = 5V, T <sub>J</sub> = 25°C		20	Ω
		I <sub>OUT</sub> = -40 mA, V <sub>CC</sub> = 5V		30	Ω
		T <sub>J</sub> = 100°C		35	Ω
		T <sub>J</sub> = 150°C			Ω
	Output Resistance (Segment Output) Temperature Coefficient			0.6	%/°C
I <sub>SOURCE</sub>	Output Source Current (Digit Output)	V <sub>CC</sub> = 4.75V, V <sub>OUT</sub> = 1.75V, T <sub>J</sub> = 150°C	-1	-2	mA
I <sub>SOURCE</sub>	Output Source Current (Carry-out)	V <sub>CC</sub> = 5V, V <sub>OUT</sub> = 0V, T <sub>J</sub> = 25°C	-1.75	-3.3	mA
I <sub>SINK</sub>	Output Sink Current (All Outputs)	V <sub>CC</sub> = 5V, V <sub>OUT</sub> = V <sub>CC</sub> , T <sub>J</sub> = 25°C	1.75	3.6	mA
θ <sub>JA</sub>	Thermal Resistance	MM74C925 (Note 4) MM74C926, MM74C927, MM74C928		75 70	100 90 °C/W

**Note 1:** "Absolute Maximum Ratings" are those values beyond which the safety of the device cannot be guaranteed. Except for "Operating Power", they are not meant to imply that the devices should be operated at these limits. The table of "Electrical Characteristics" provides conditions for actual device operation.

**Note 2:** Capacitance is guaranteed by periodic testing.

**Note 3:** C<sub>PD</sub> determines the no load ac power consumption of any CMOS device. For complete explanation see 54C/74C Family Characteristics application note, AN-90.

**Note 4:** θ<sub>JA</sub> measured in free-air with device soldered into printed circuit board.

ac electrical characteristics  $T_j = 25^\circ\text{C}$ ,  $C_L = 50\text{ pF}$ , unless otherwise specified

PARAMETER		CONDITIONS		MIN	TYP	MAX	UNIT
$f_{\text{MAX}}$	Maximum Clock Frequency	$V_{\text{CC}} = 5.0\text{V}$ , Square Wave Clock	$T_j = 25^\circ\text{C}$ $T_j = 100^\circ\text{C}$	2 1.5	4 3		MHz MHz
$t_r, t_f$	Maximum Clock Rise or Fall Time	$V_{\text{CC}} = 5.0\text{V}$				15	ns
$t_{\text{WR}}$	Reset Pulse Width	$V_{\text{CC}} = 5.0\text{V}$	$T_j = 25^\circ\text{C}$ $T_j = 100^\circ\text{C}$	250 320	100 125		ns ns
$t_{\text{WE}}$	Latch Enable Pulse Width	$V_{\text{CC}} = 5.0\text{V}$	$T_j = 25^\circ\text{C}$ $T_j = 100^\circ\text{C}$	250 320	100 125		ns ns
$t_{\text{SETCK,LEI}}$	Clock to Latch Enable Set-Up Time	$V_{\text{CC}} = 5.0\text{V}$	$T_j = 25^\circ\text{C}$ $T_j = 100^\circ\text{C}$	2500 3200	1250 1600		ns ns
$t_{\text{LR}}$	Latch Enable to Reset Wait Time	$V_{\text{CC}} = 5.0\text{V}$	$T_j = 25^\circ\text{C}$ $T_j = 100^\circ\text{C}$	0 0	-100 -100		ns ns
$t_{\text{SETIN,LEI}}$	Reset to Latch Enable Set-Up Time	$V_{\text{CC}} = 5.0\text{V}$	$T_j = 25^\circ\text{C}$ $T_j = 100^\circ\text{C}$	320 400	160 200		ns ns
$f_{\text{MUX}}$	Multiplexing Output Frequency	$V_{\text{CC}} = 5.0\text{V}$			1000		Hz
$C_{\text{IN}}$	Input Capacitance	Any Input (Note 2)			5		pF

typical performance characteristics

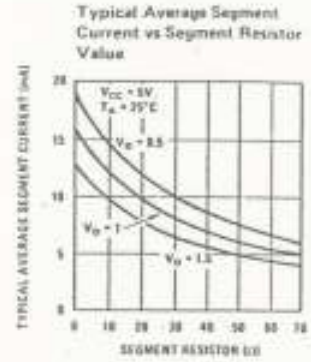
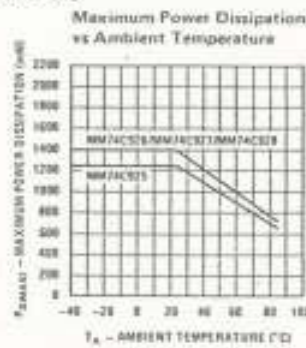
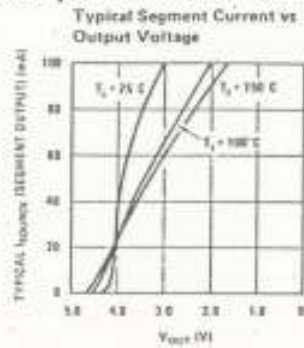

Note,  $V_0$  = Voltage across digit driver.

logic and block diagrams

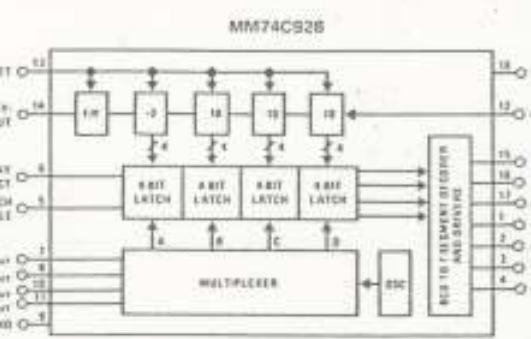
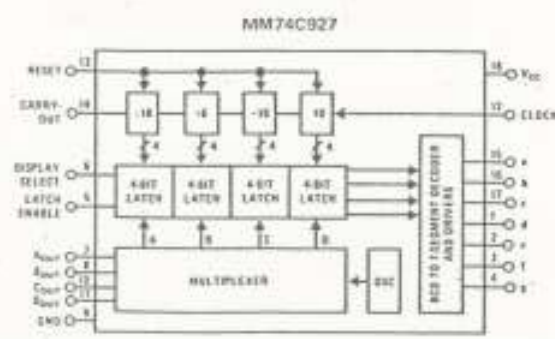
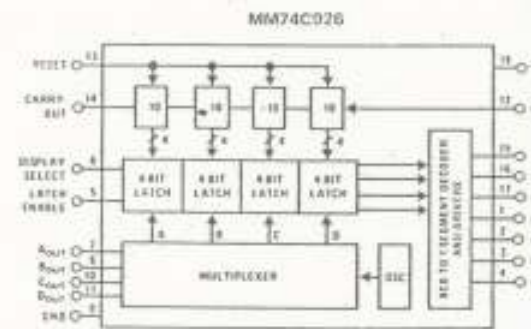
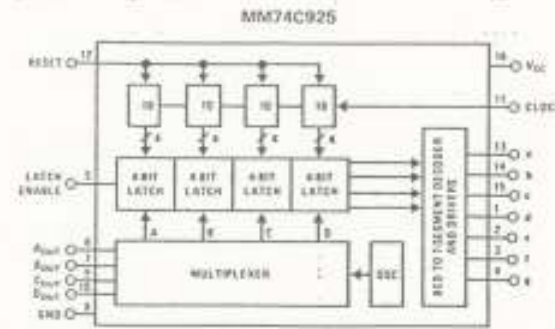

Segment Output Driver

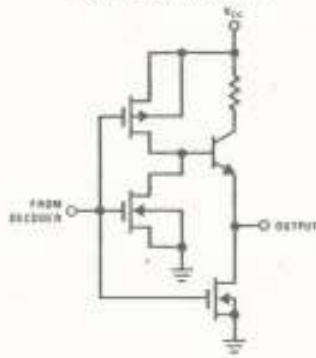

Input Protection

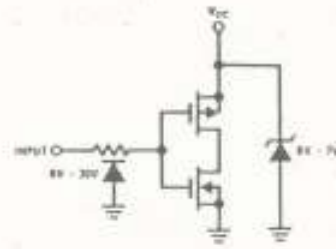

Common Cathode LED Display

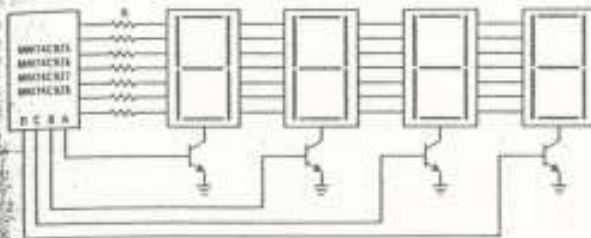

Segment Identification

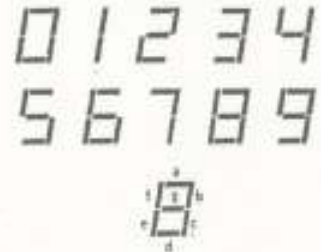

switching time waveforms

